

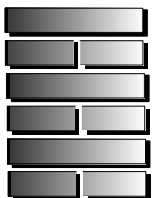
Revised May 16, 2005

# DRAFT

---

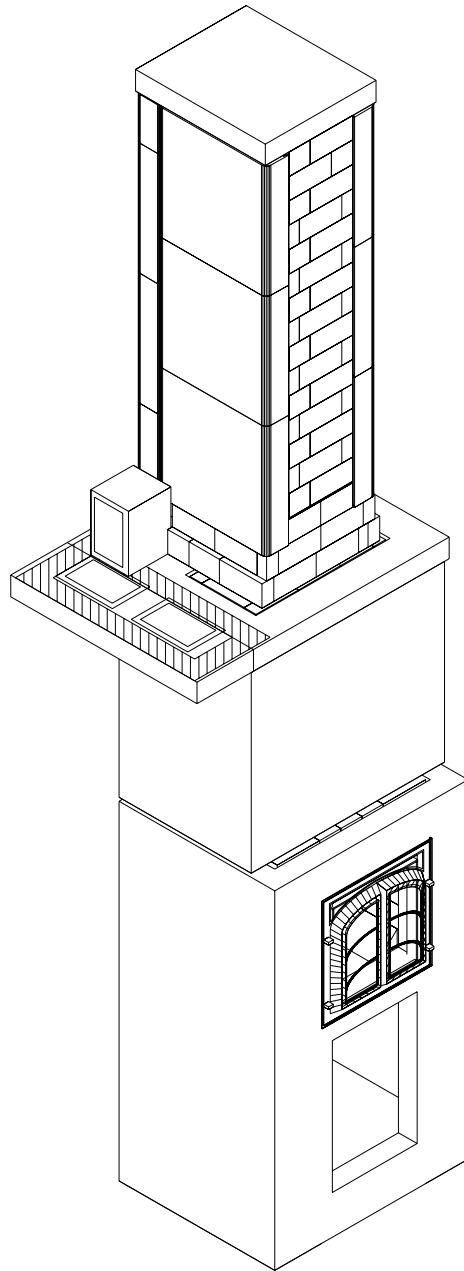
## Assembly Manual

HK22" basement firebox with custom upstairs heat battery.

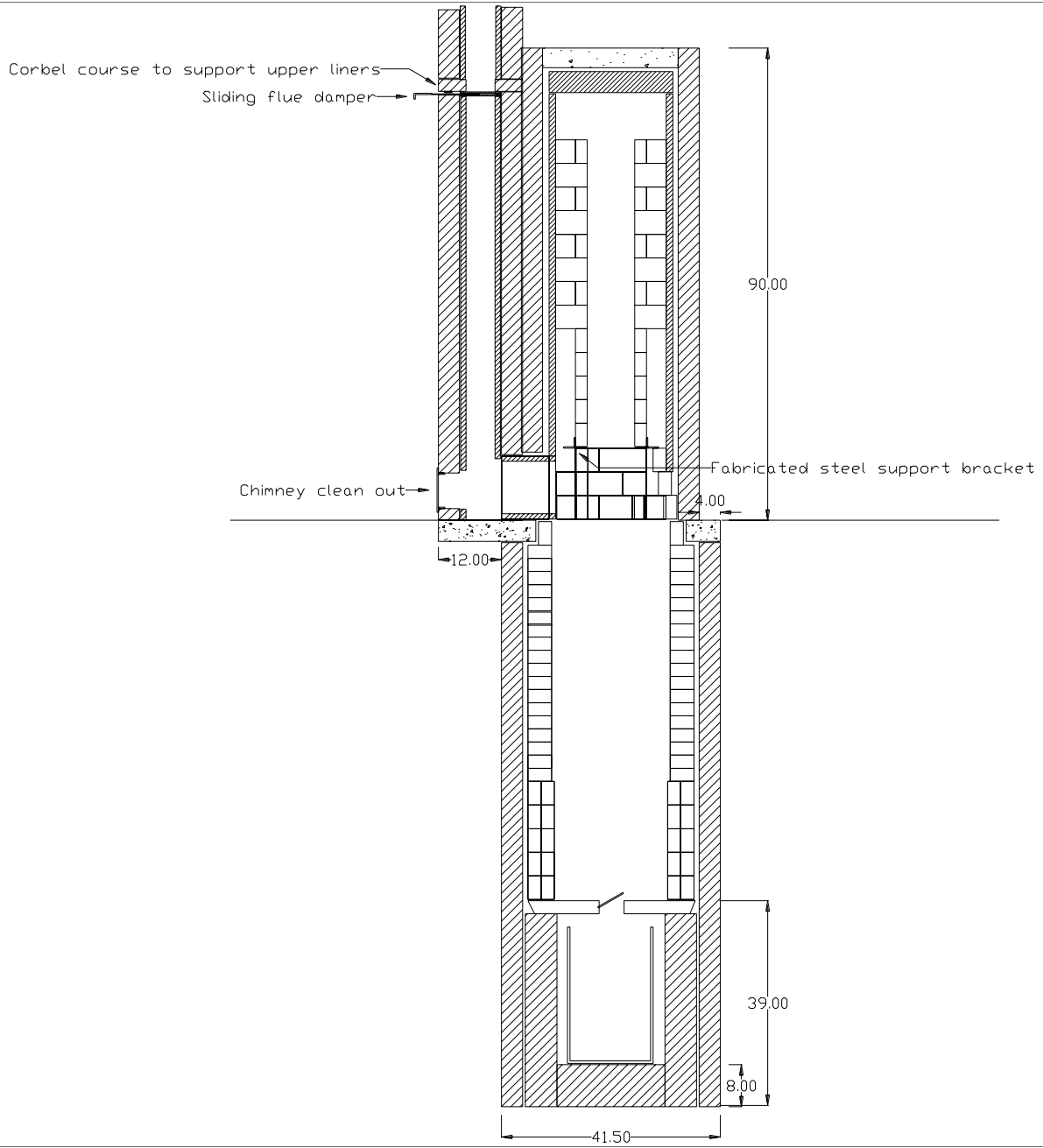


**Masonry Stove  
Builders**

RR 5 Shawville Québec J0X 2Y0  
819 647 5092  
fax 647 6082  
mheat@mha-net.org (Norbert Senf)  
[www.heatkit.com](http://www.heatkit.com)



**Figure 1**



**Figure 2**

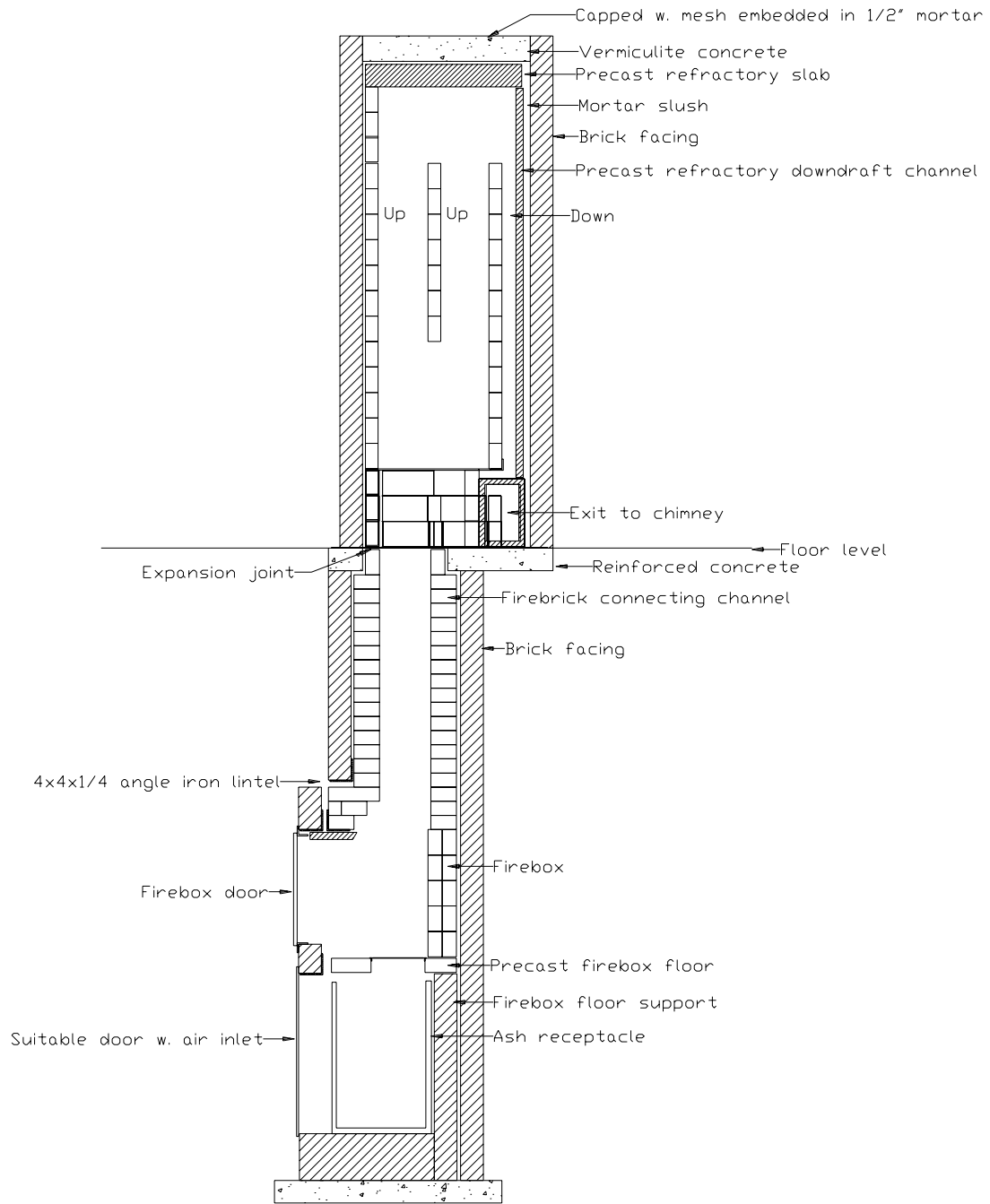
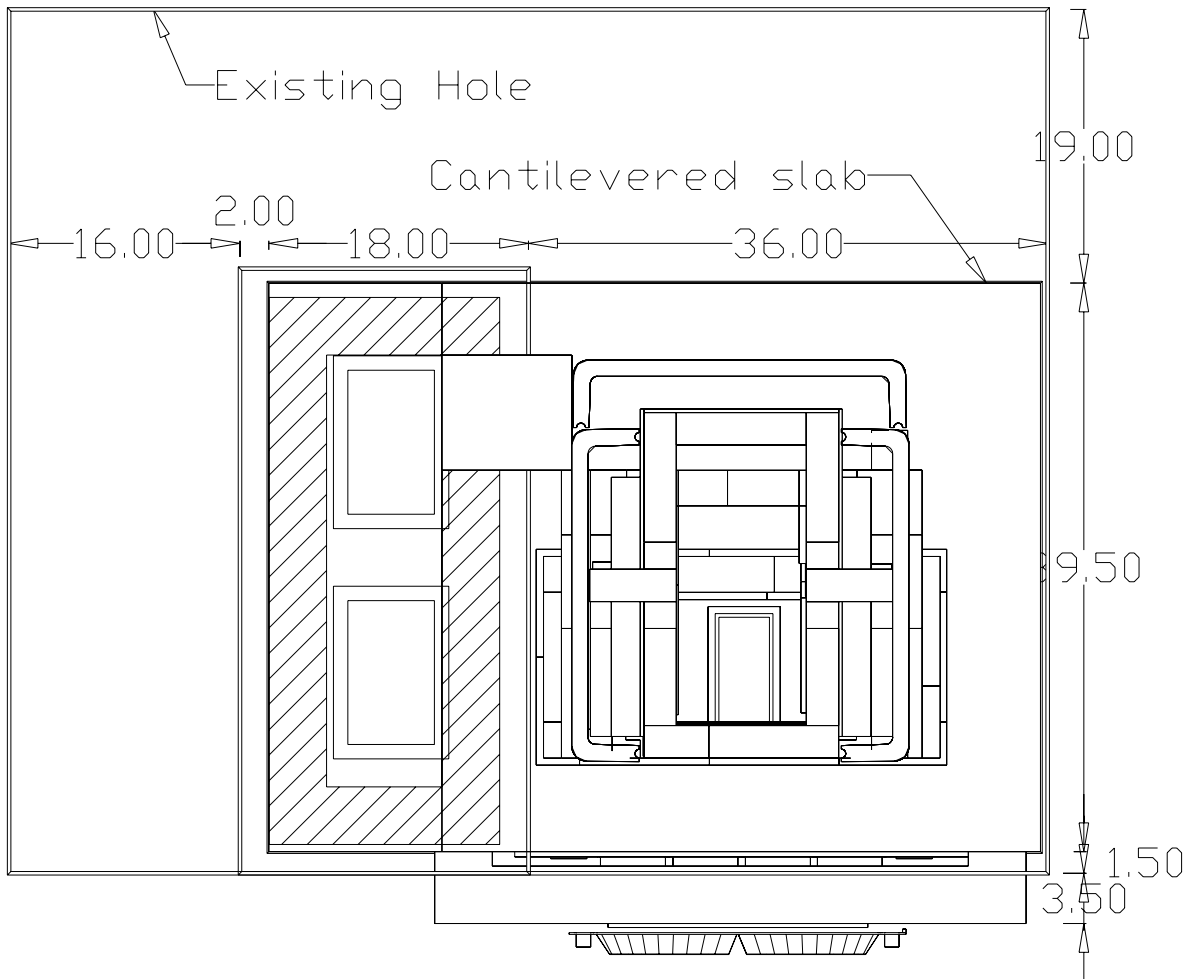
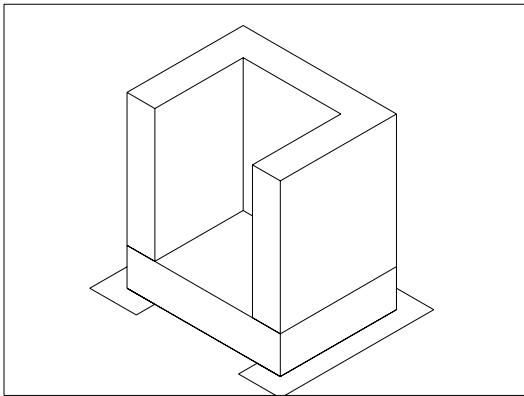


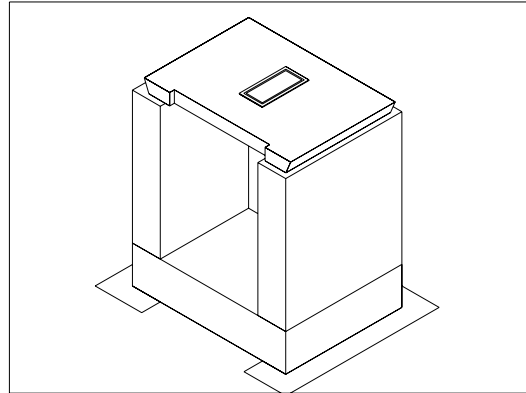
Figure 3



**Figure 4**

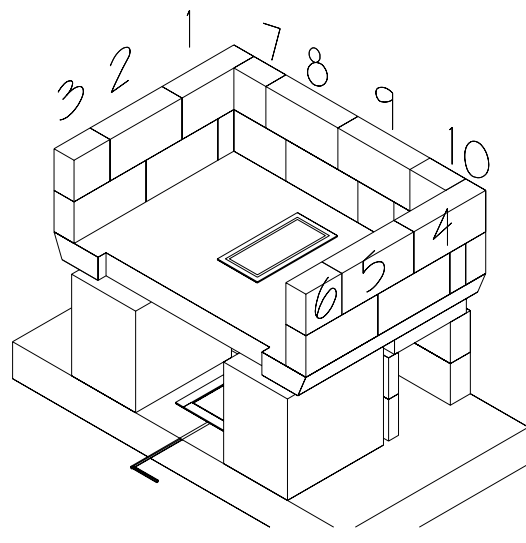
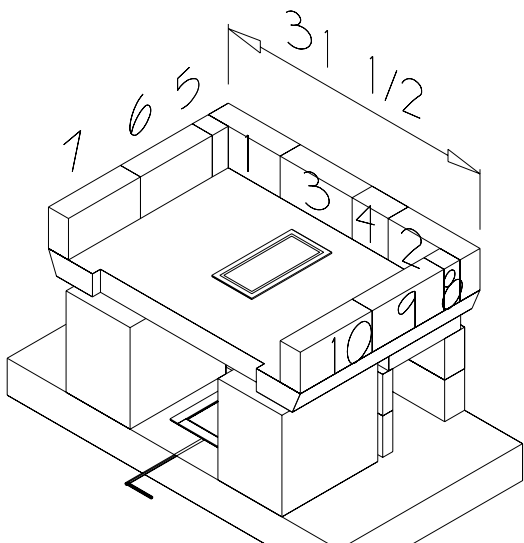


**Figure 5**



**Figure 6**

Firbox assembly sequence below is taken from our standard core assembly manual. Ignore the parts outside the firebox.

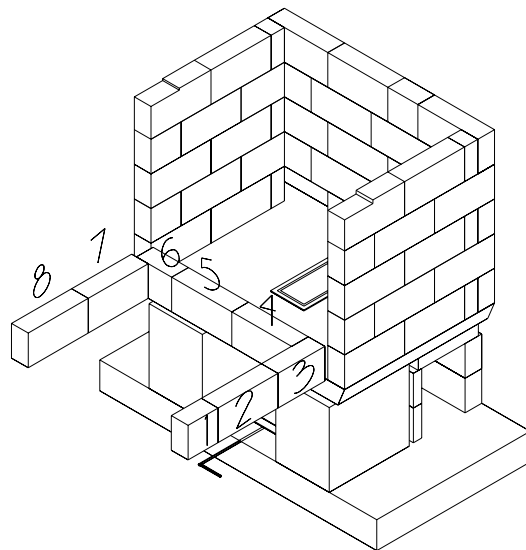
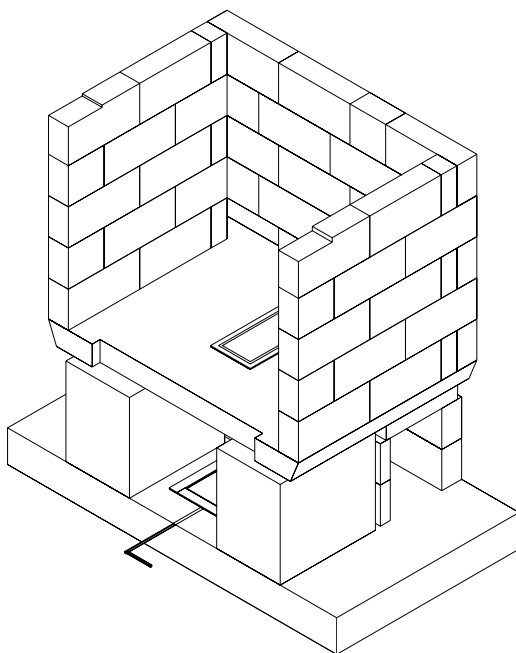
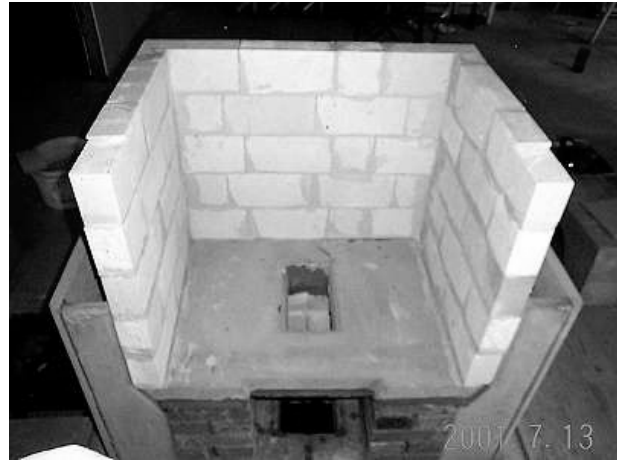
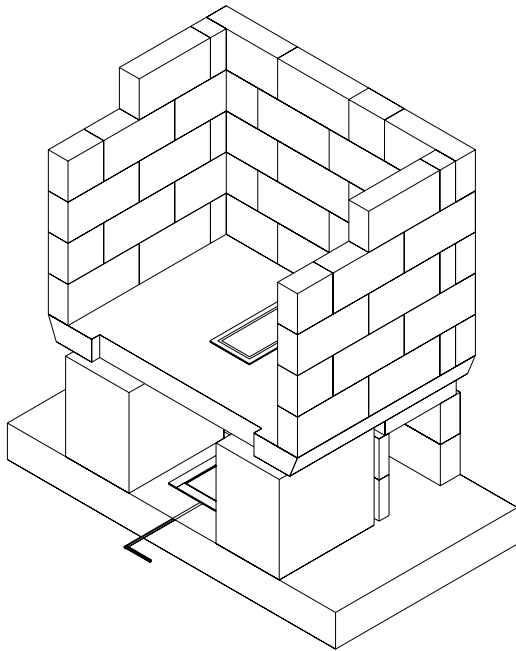


Lay out the firebox as indicated, using air setting refractory mortar. Line up back corners with the leads that are precast into the lower channels (right channel deleted from drawings for clarity).

Exact bond is dependent on firebrick thickness, generally between 2-1/4" and 2-1/2".

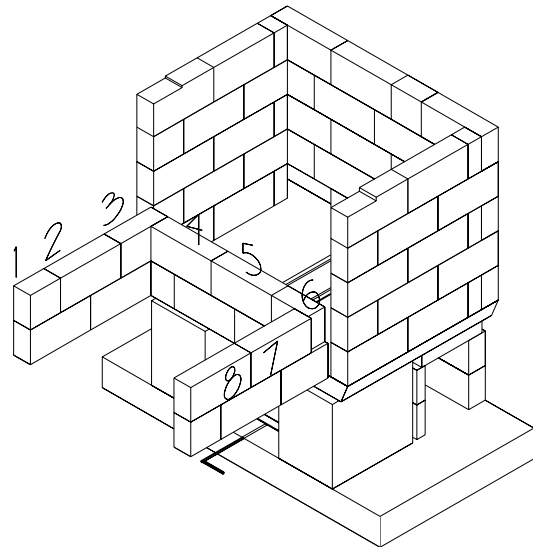
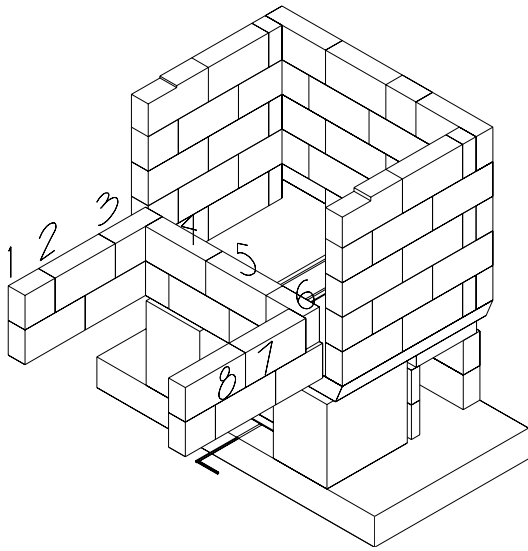
Outer width of firebox is 31 1/2". Firebricks sit dry against base channels.

**Error! Reference source not found.** shows the firebricks numbered in the order in which they are installed.

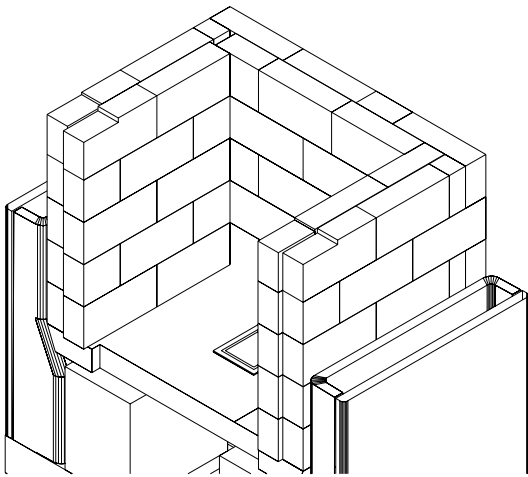


Top front firebricks are notched 1/4" x 4" for firebox lintel.

Begin inner firebox. Note that the bricks are left about 1/4" short at the blind inside corners. The cut edges on these bricks are hidden.



The inner firebox is set dry against the outer firebox. There is no mortar joint between the two fireboxes.

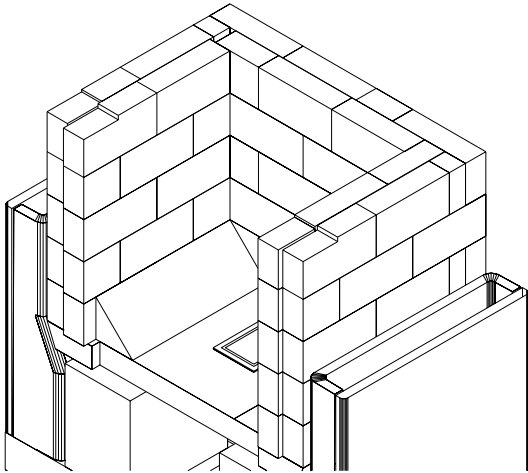


Notch top course of liner as shown. Notches are 1/4" x 4"

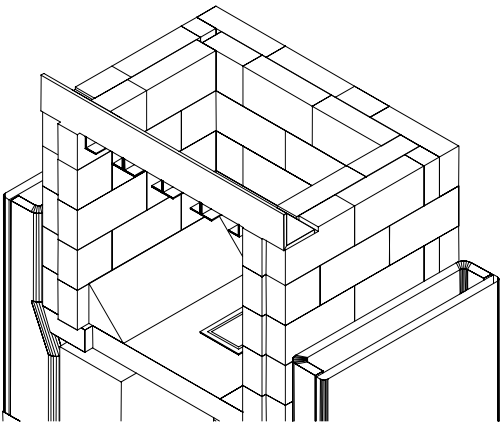


Immediately wash down the firebox with a sponge and a liberal amount of water. Rinse with clean water. If this is done right away, it is easy to get a clean looking firebox.

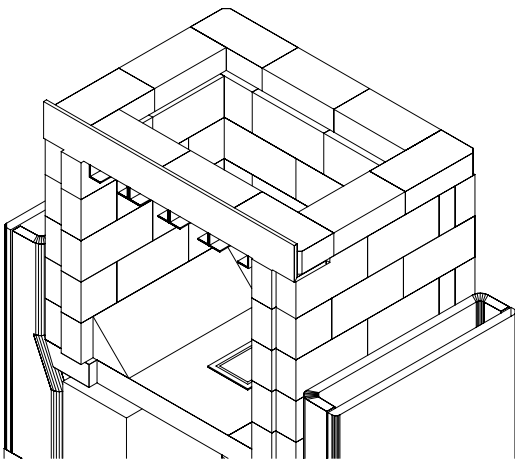




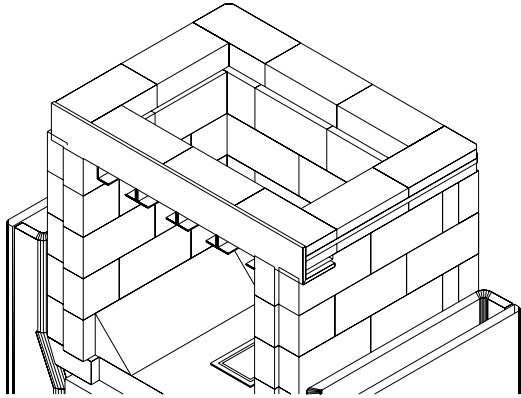
Firebrick floor slopes are glued in place with Sairset - this can be done later.



Install firebox lintel. Brackets on lintel are for heat shields (firebrick splits, installed later, see **Error! Reference source not found.**).



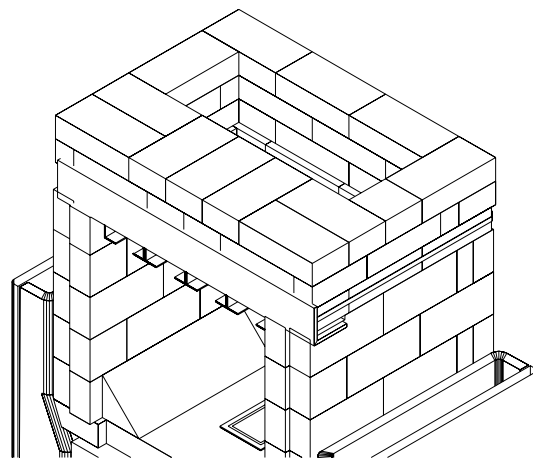
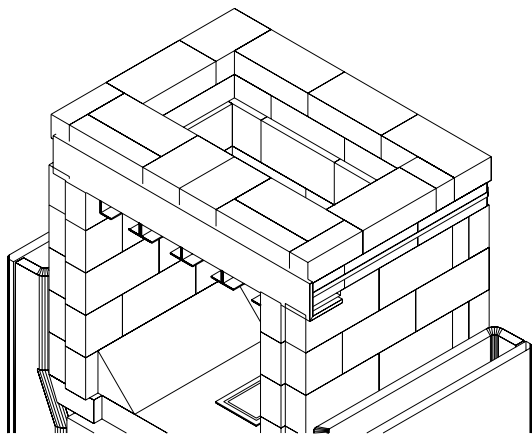
Lay up next course as shown. Use a dry joint with lintel.



If you have access to strapping tools, this course can be strapped as shown. This is optional. If a strap is used, then round outside corners of bricks slightly.

The purpose of the strap is to transfer weight onto the outer firebox.

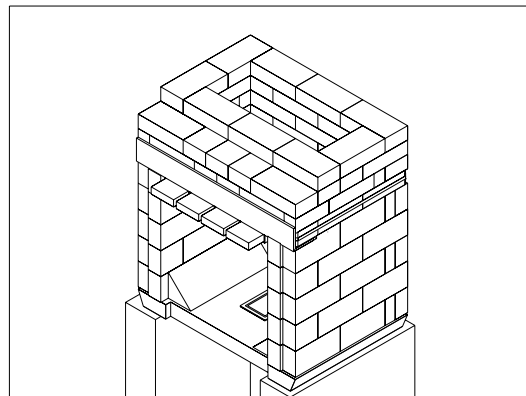
This allows the complete inner firebox to be removed, if necessary, rather than in sections.



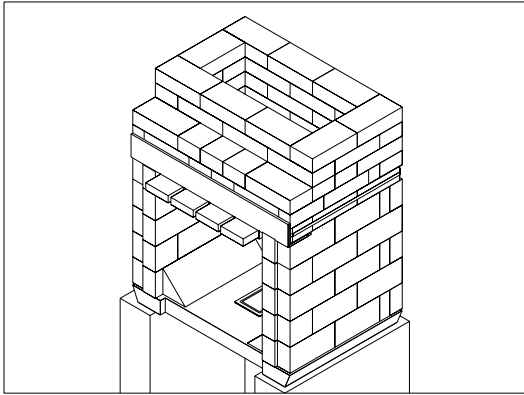
A total of 10 soaps (5 bricks ripped lengthwise) is used. All bricks are either full length (9"), 3/4 length (6 3/4") or half length (4 1/2")

Next course.

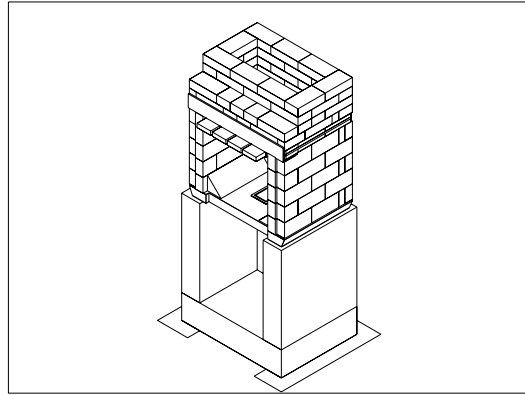
(End of standard firebox sequence)



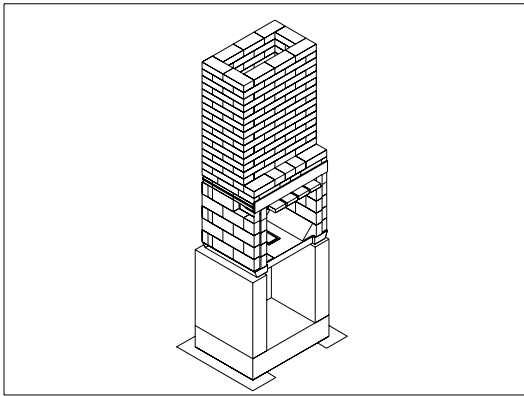
**Figure 7**



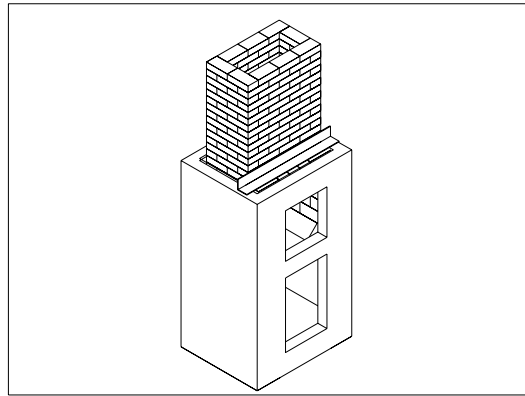
**Figure 8**



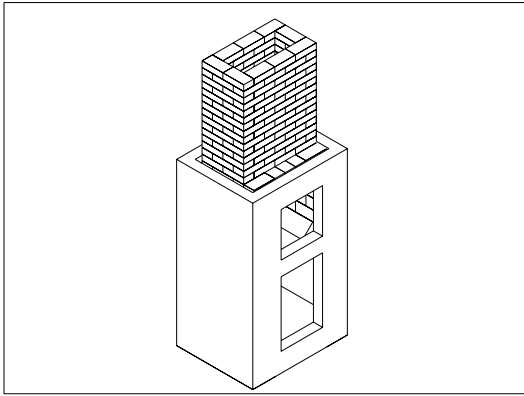
**Figure 9. Viewed from right side**



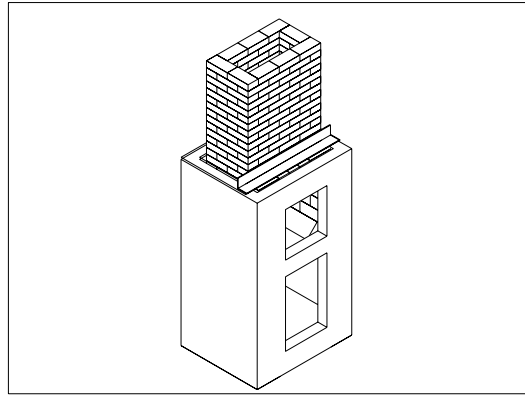
**Figure 10. Viewed from left side**



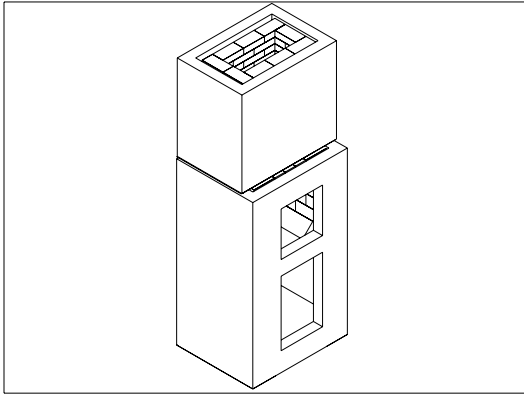
**Figure 11**



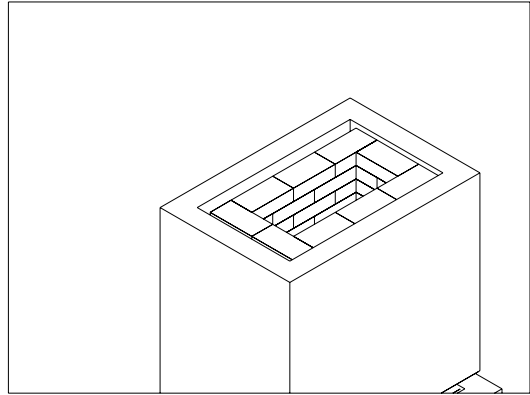
**Figure 12**



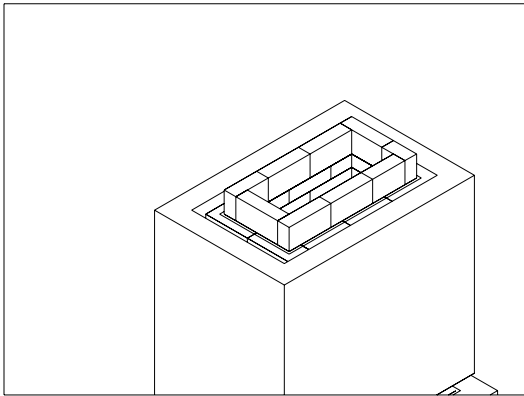
**Figure 13**



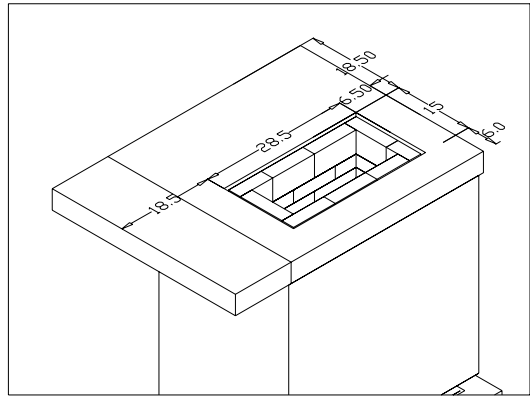
**Figure 14**



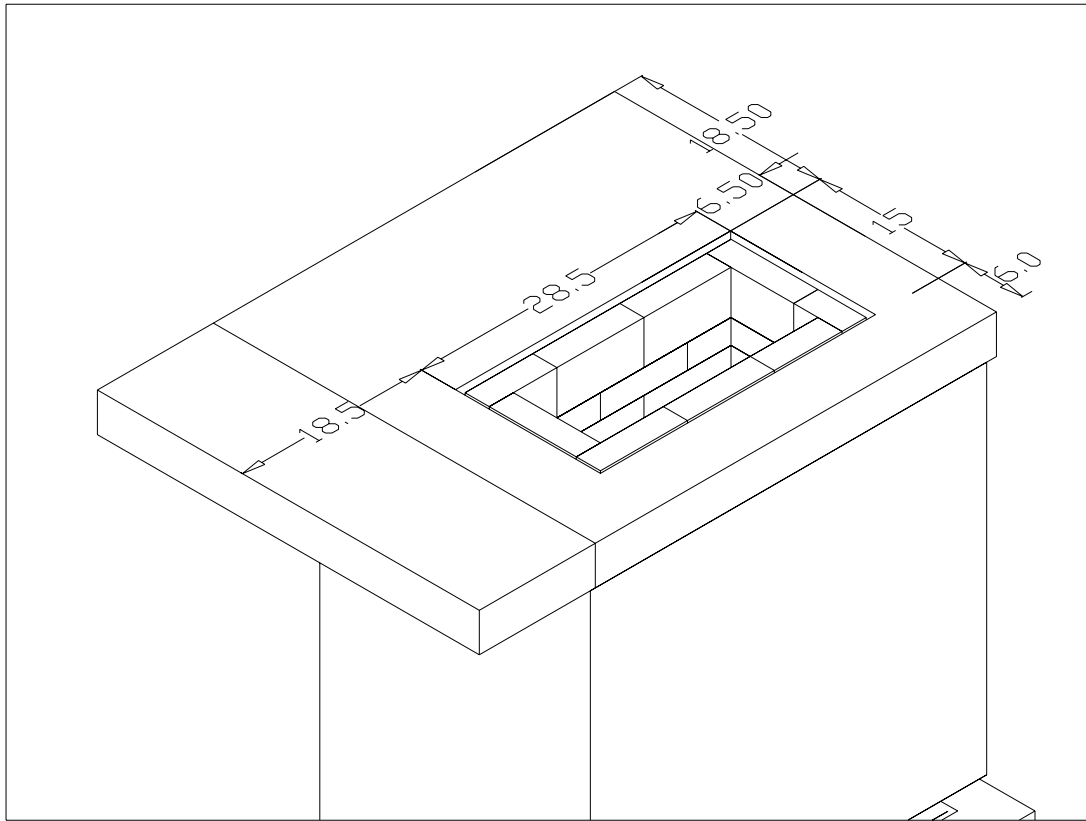
**Figure 15**



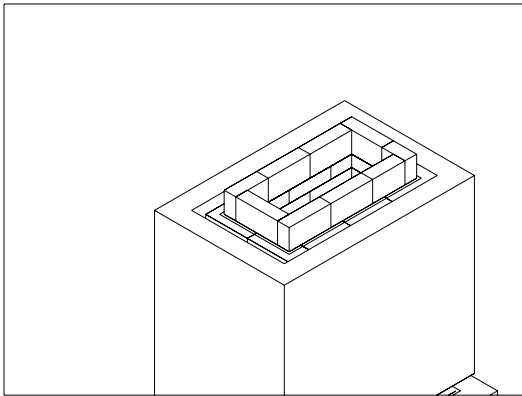
**Figure 16**



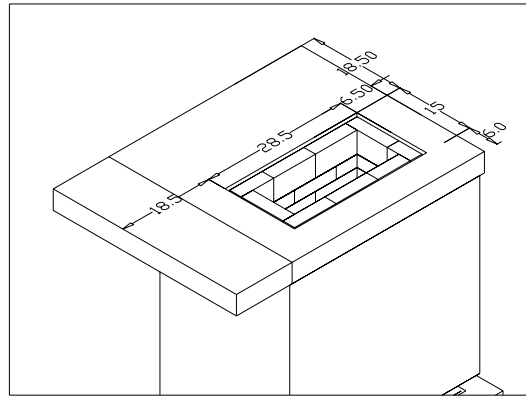
**Figure 17**



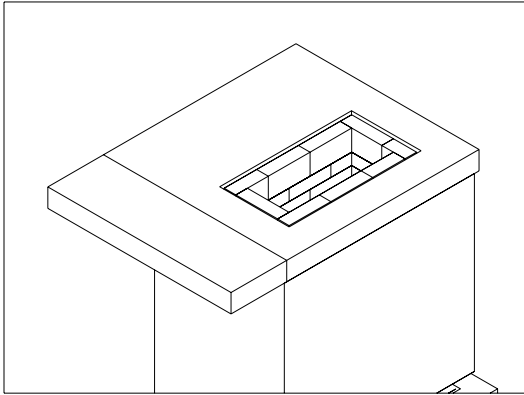
**Figure 18**



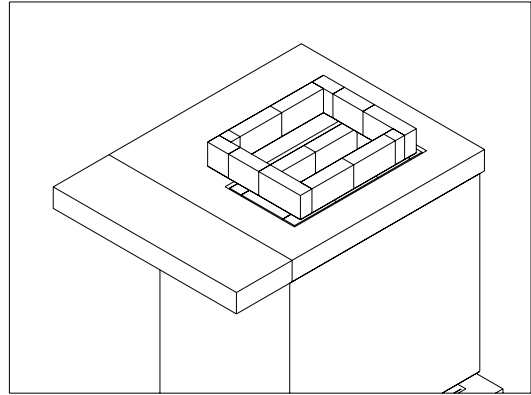
**Figure 19**



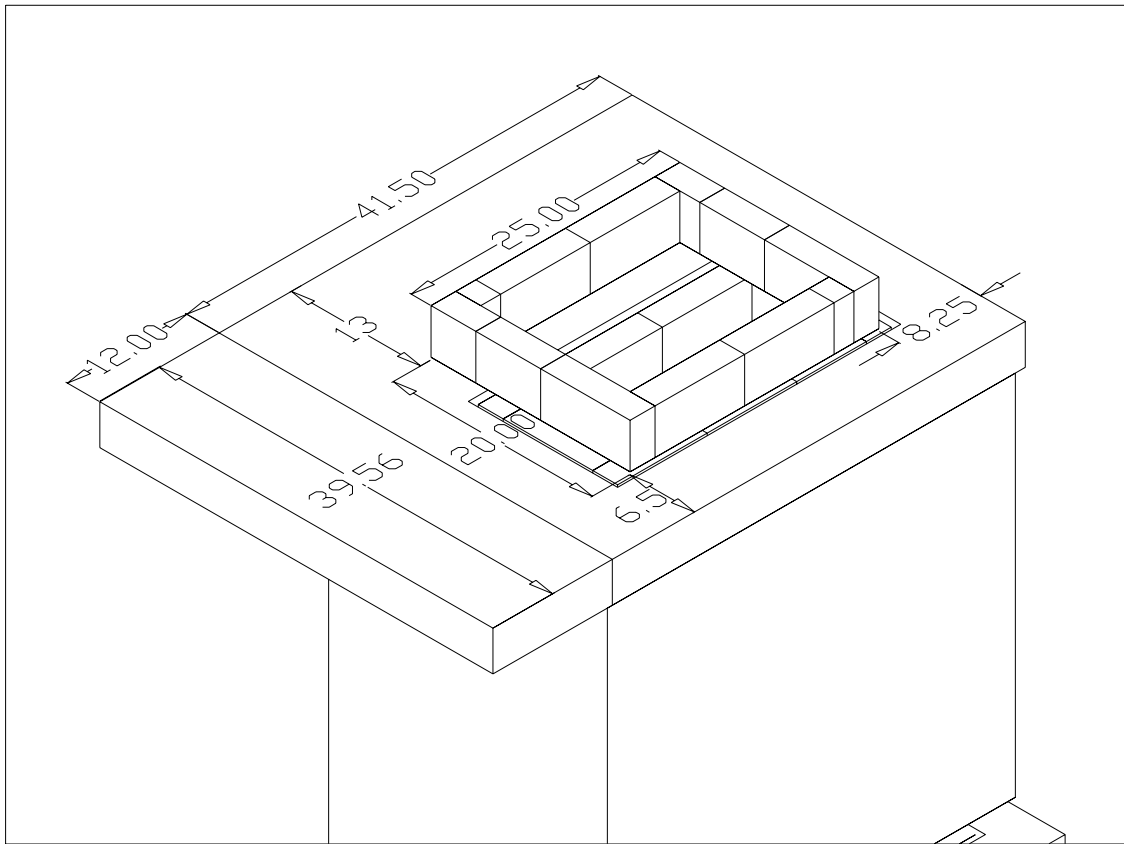
**Figure 20**



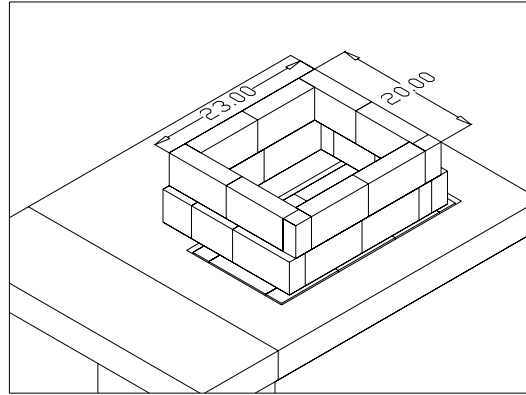
**Figure 21**



**Figure 22**



**Figure 23**



**Figure 24**

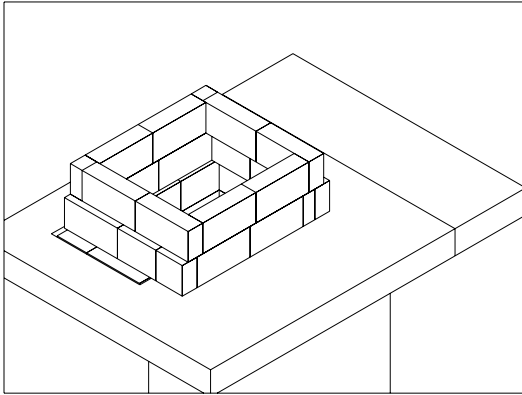


Figure 25

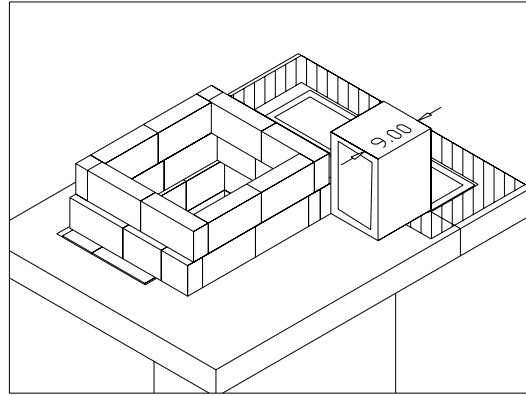


Figure 26

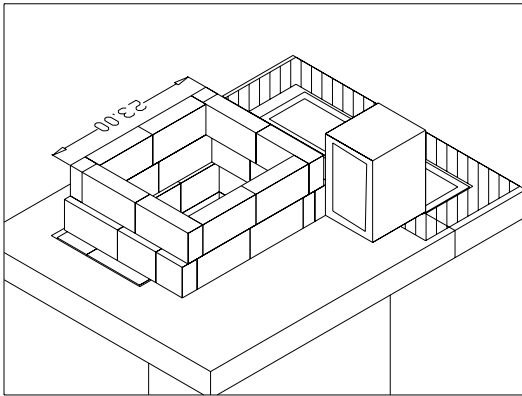


Figure 27

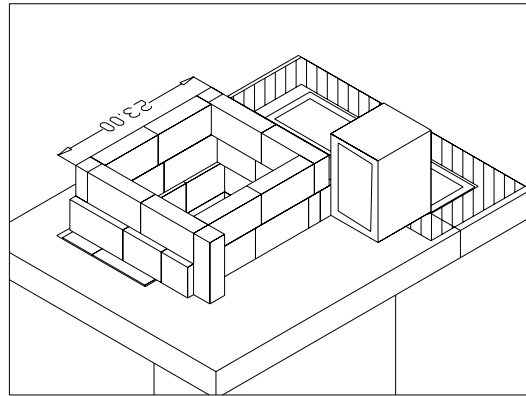


Figure 28

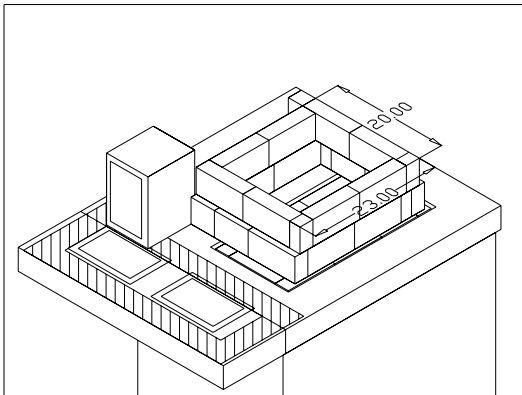


Figure 29

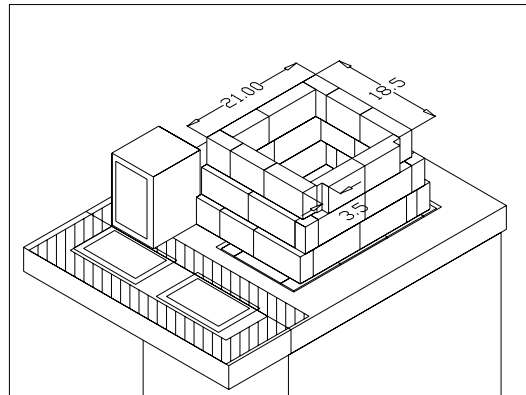
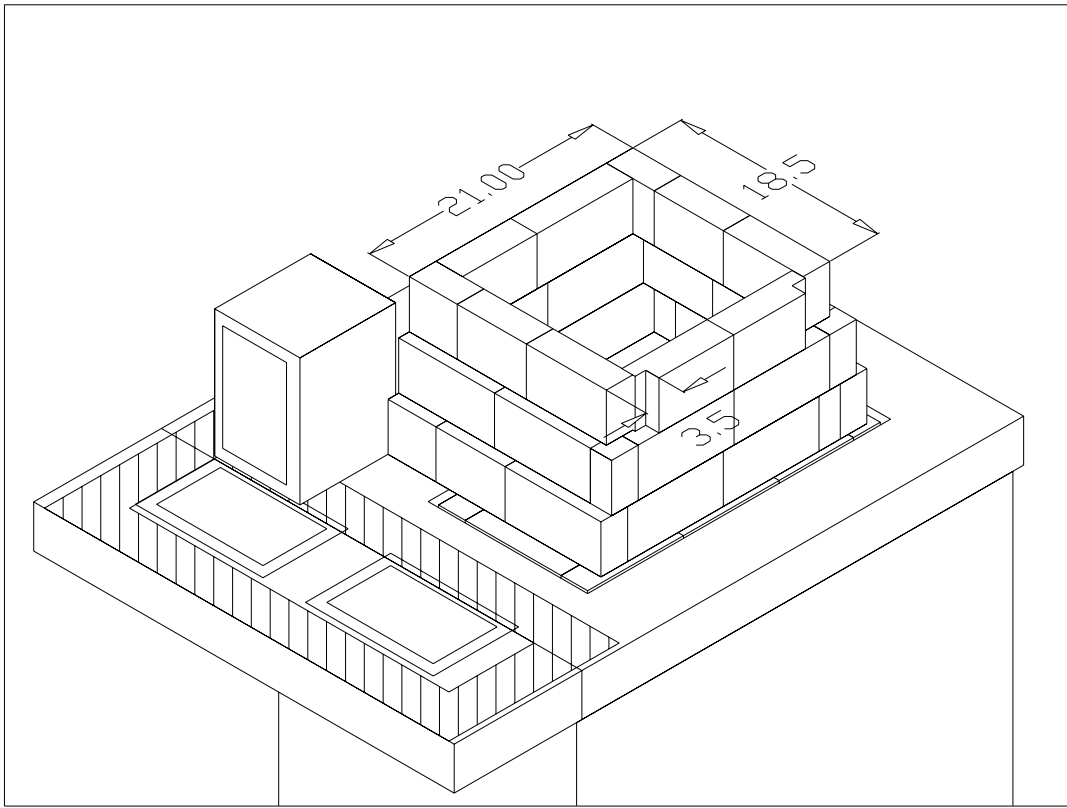
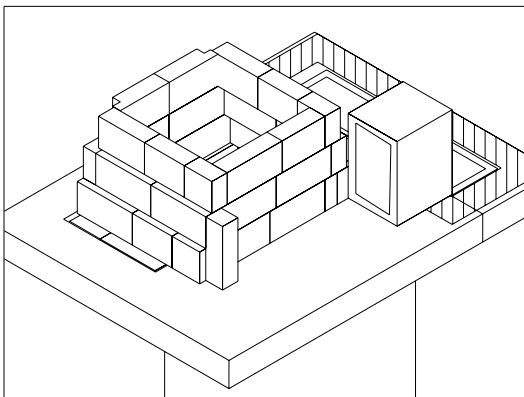


Figure 30

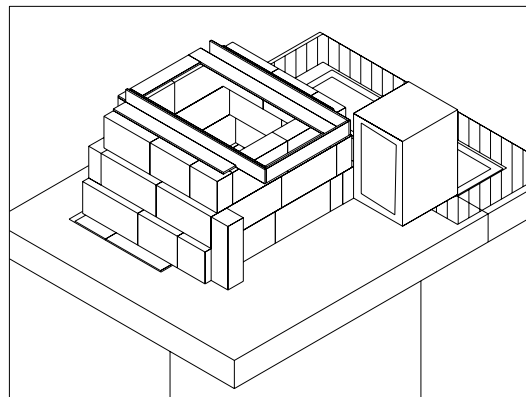




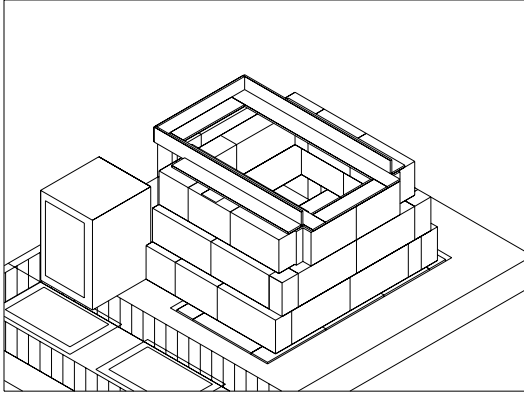
**Figure 31**



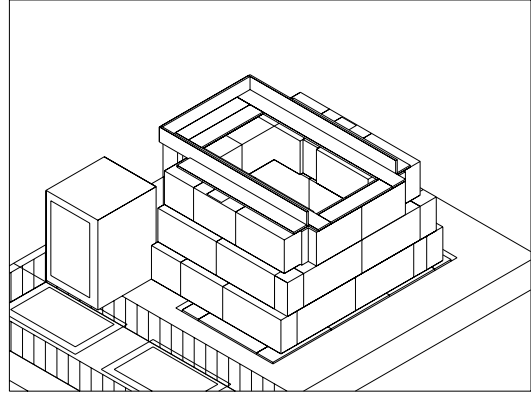
**Figure 32**



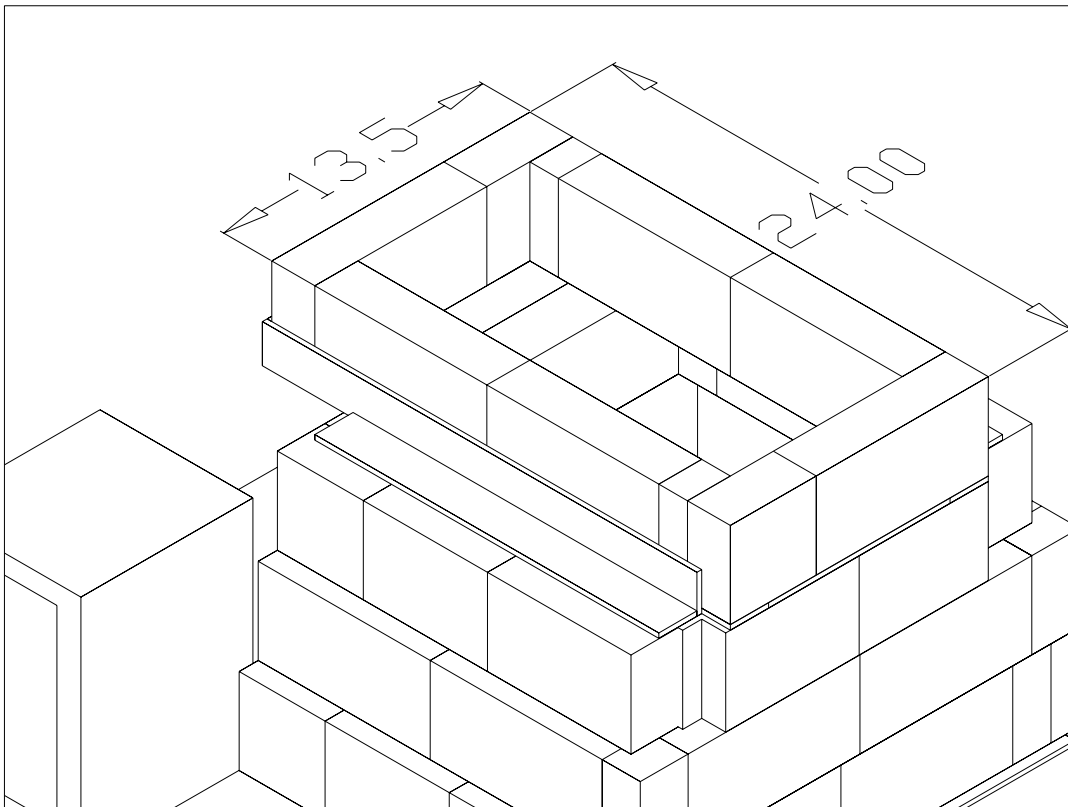
**Figure 33**



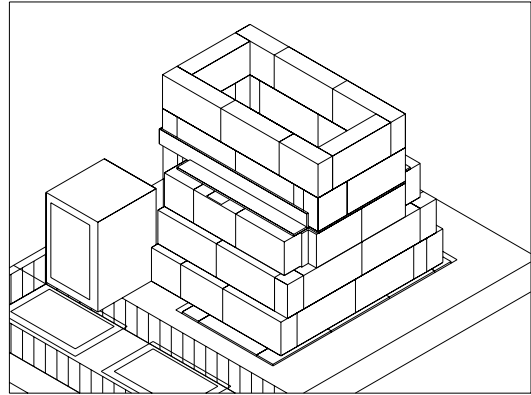
**Figure 34**



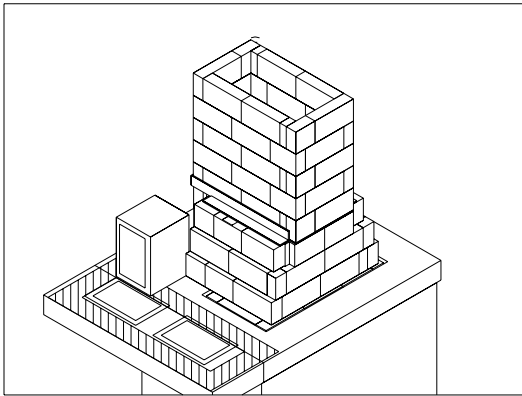
**Figure 35**



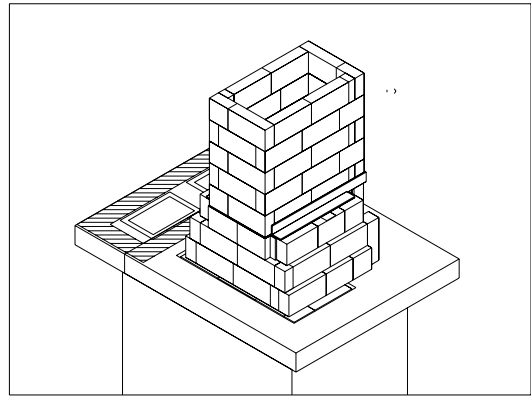
**Figure 36**



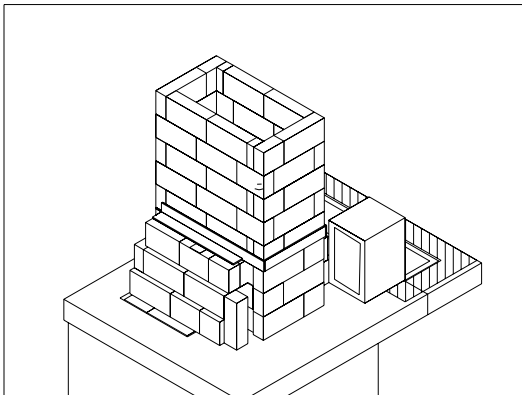
**Figure 37**



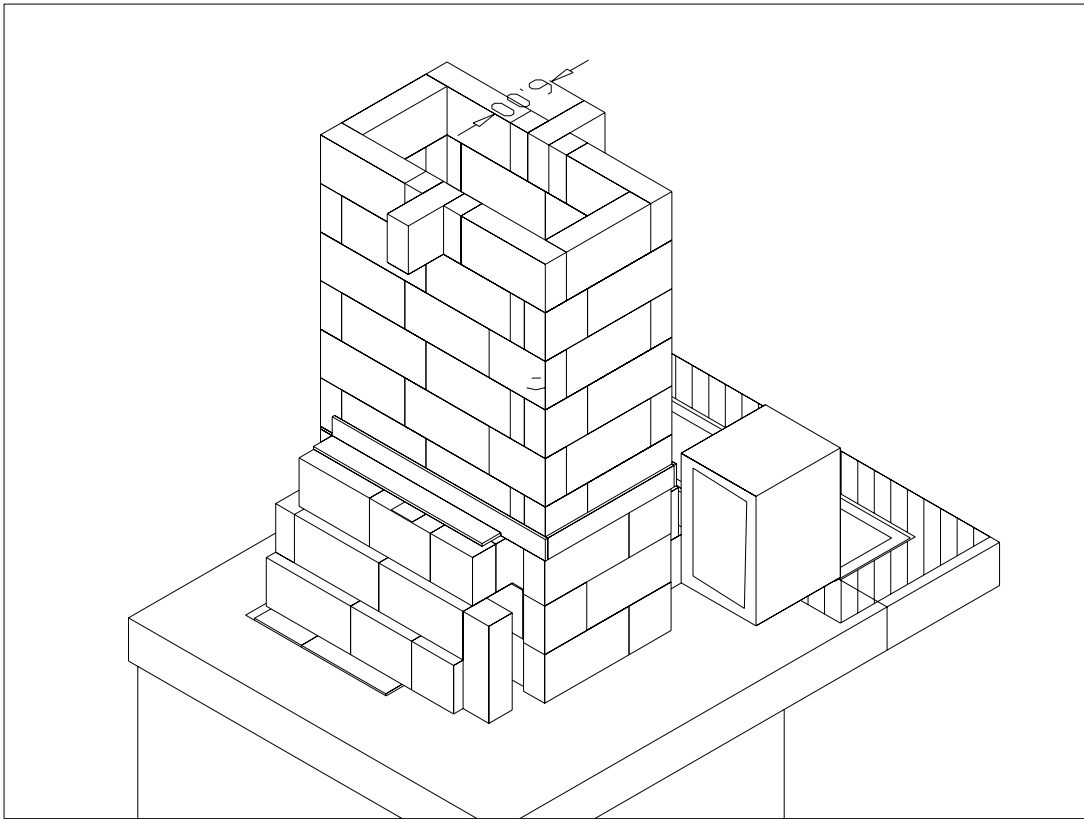
**Figure 38**



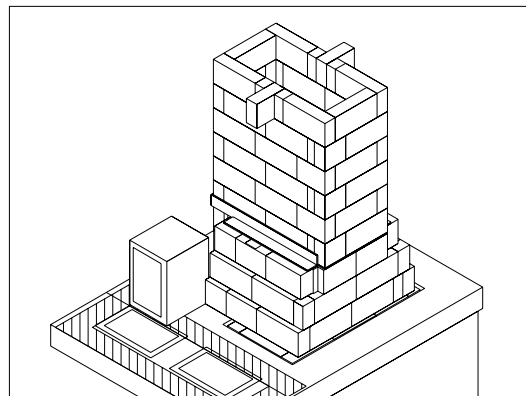
**Figure 39**



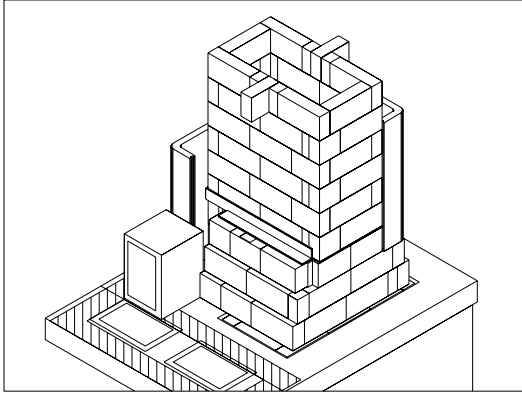
**Figure 40**



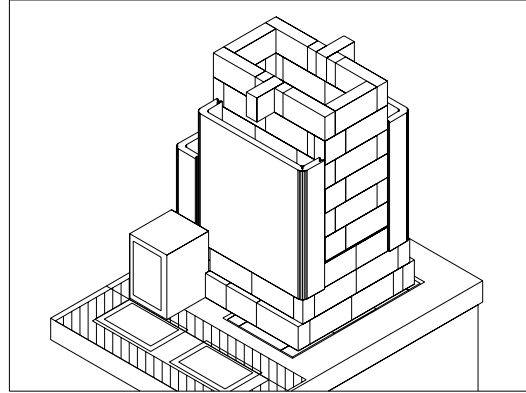
**Figure 41**



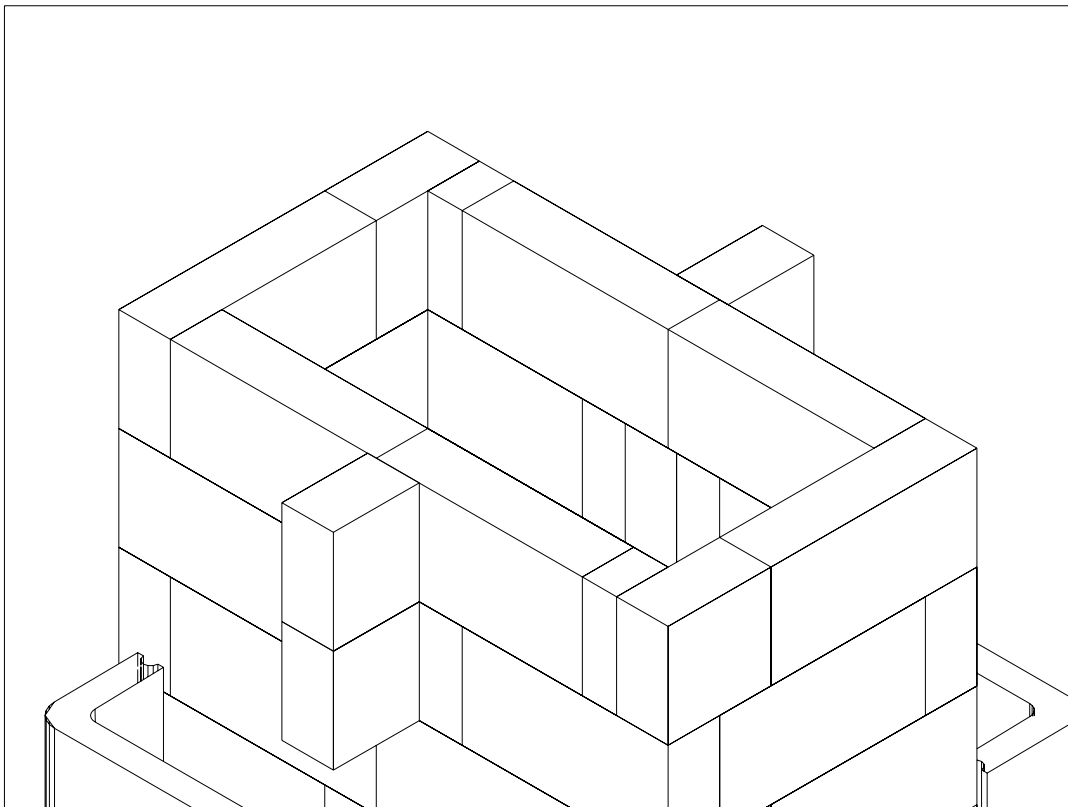
**Figure 42**



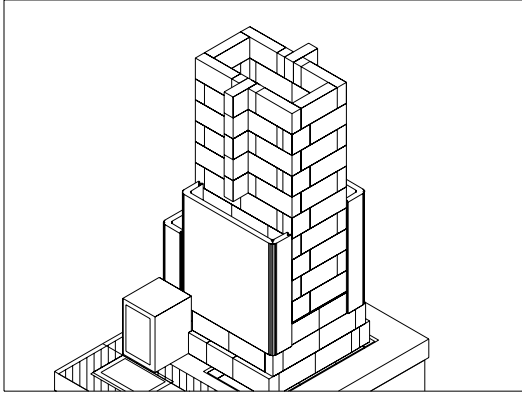
**Figure 43**



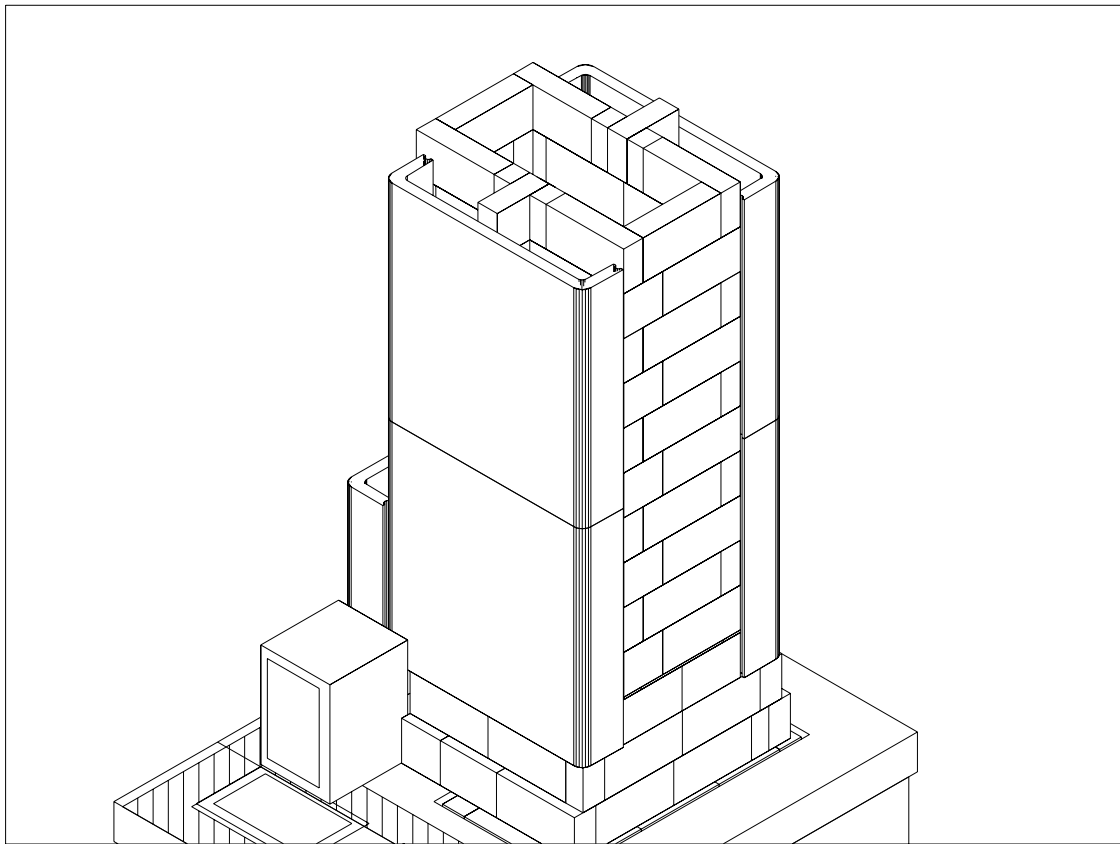
**Figure 44**



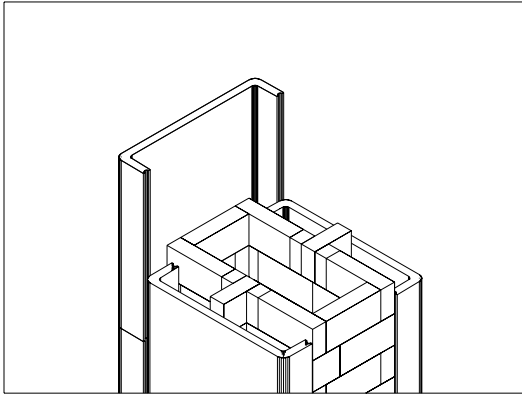
**Figure 45**



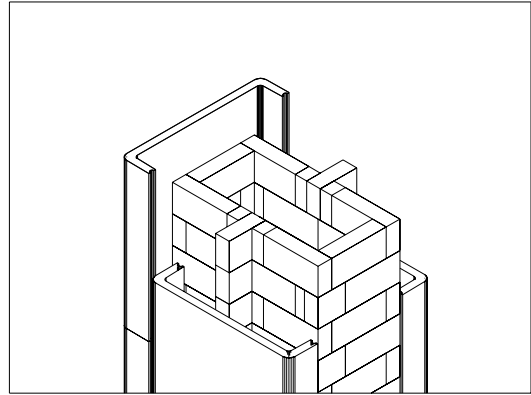
**Figure 46**



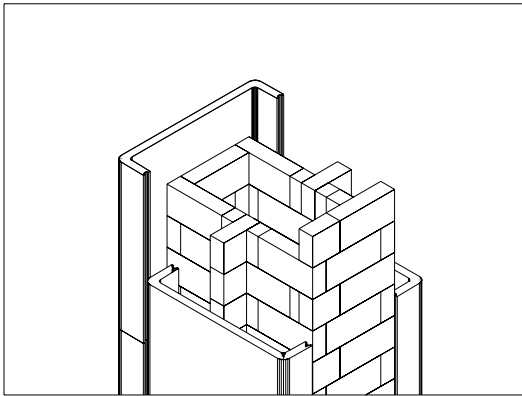
**Figure 47**



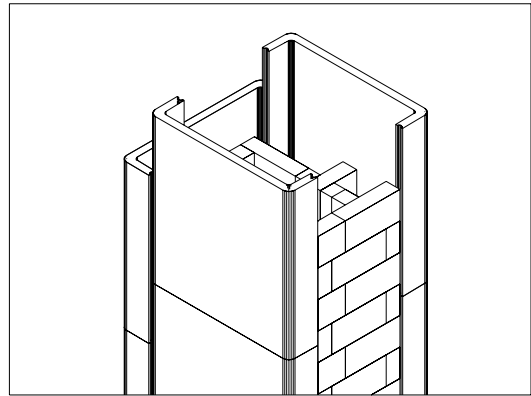
**Figure 48**



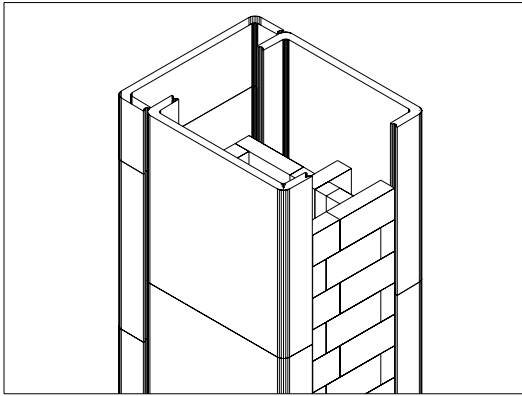
**Figure 49**



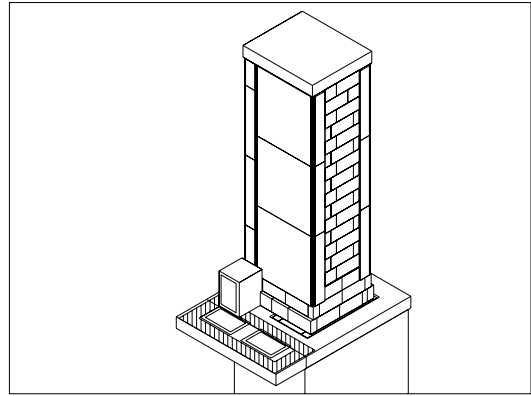
**Figure 50**



**Figure 51**



**Figure 52**



**Figure 53**

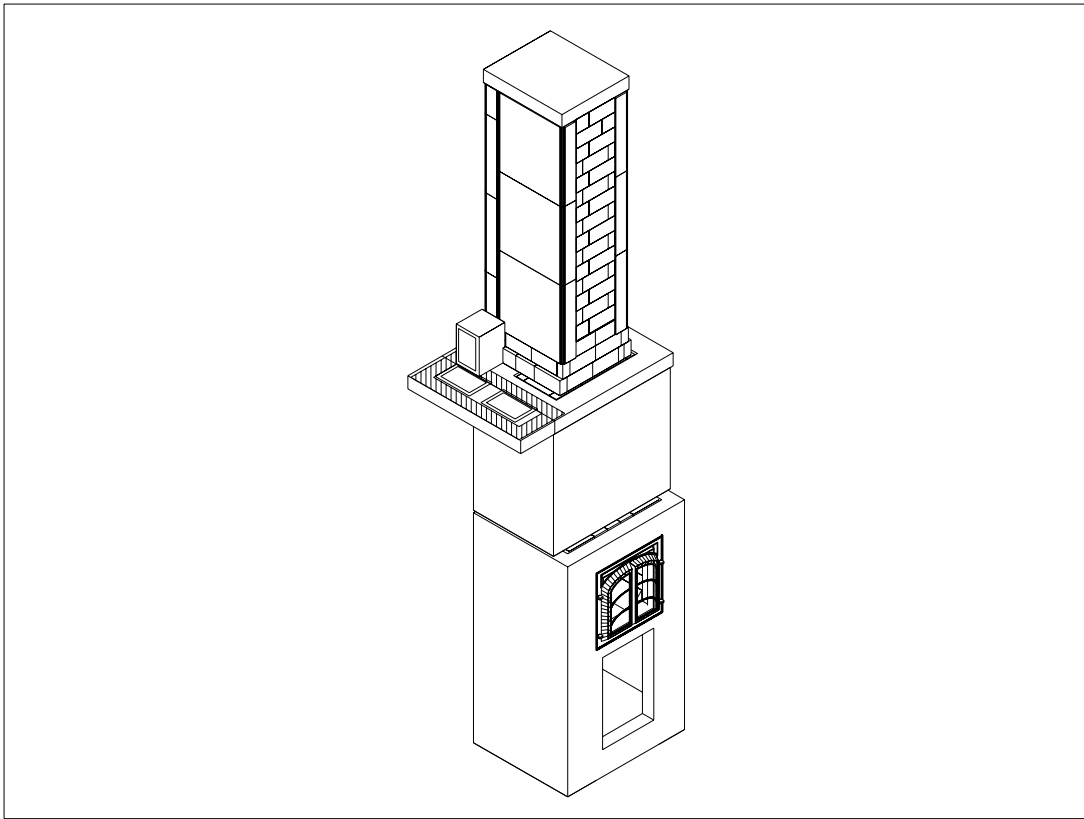


Figure 54